

推奨ランドパターン (参考) Recommended Land Pattern (Reference)

電極パターン(基板表面): AM11DP-ST01*[特許取得済み]
Land pattern (Surface of the Substrate) [Patented]

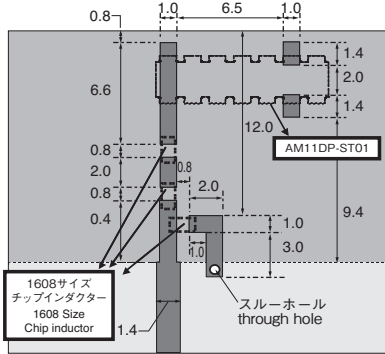

[Units : mm]

基板全体図(基板表面): AM11DP-ST01*
Evaluated board (Surface of the Substrate)

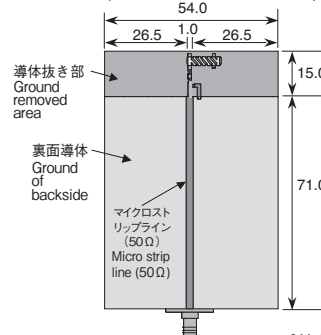

[Units : mm]

電極パターン(基板表面): AM03DP-ST01*[特許取得済み]
Land pattern (Surface of the Substrate) [Patented]

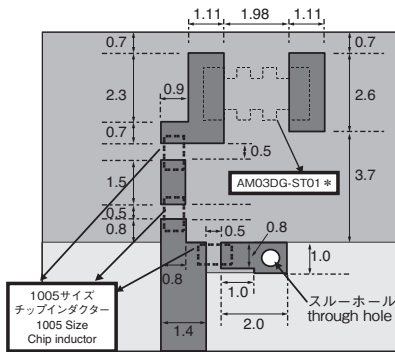

[Units : mm]

基板全体図(基板表面): AM03DP-ST01*
Evaluated board (Surface of the Substrate)

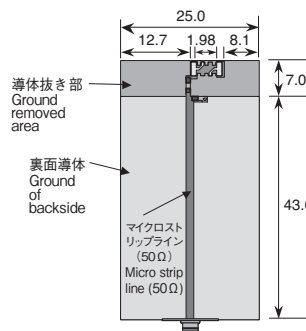

[Units : mm]

電極パターン(基板表面): AW03DP-245ST01*[特許申請中]
Land pattern (Surface of the Substrate) [Patent Pending]

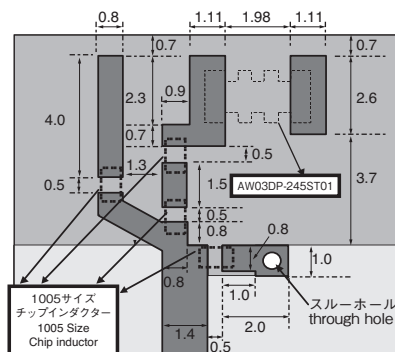

[Units : mm]

基板全体図(基板表面): AW03DP-245ST01*
Evaluated board (Surface of the Substrate)

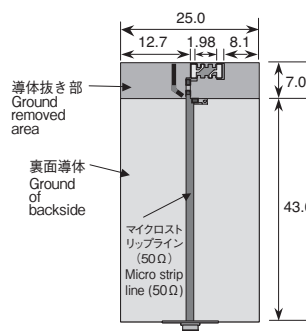

[Units : mm]