

1.27mm (0.050") Box Header Straight Type

MATERIALS

Insulator :PA6T+30%Glass Fiber,
UL94V-0
Contact :Brass
Contact Plating :Gold/Tin over Nickel

SPECIFICATONS

Current Rating :1A
Operation Temperature :-40°C to +105°C
Insulation Resistance :1000MΩ Min
contact resistance :30mΩ Max
Processing Temperature:260°C for 10 seconds

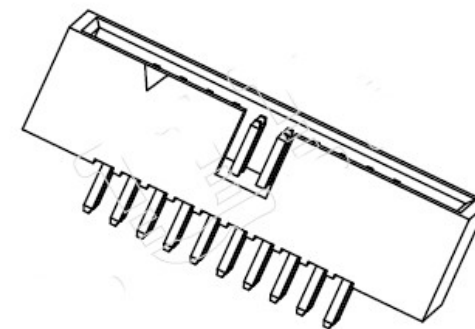
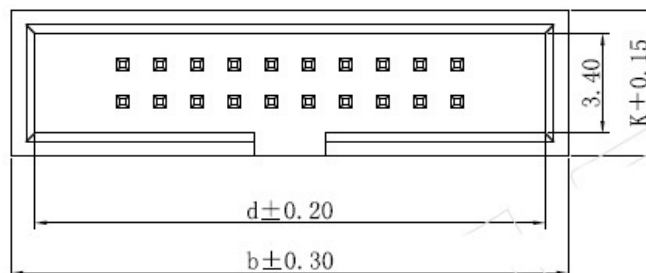

$a = 1.27 \times (\text{No. of pins per row} - 1)$
 $b = 1.27 \times (\text{No. of pins per row}) + 6.35$
 $d = 1.27 \times (\text{No. of pins per row}) + 4.75$

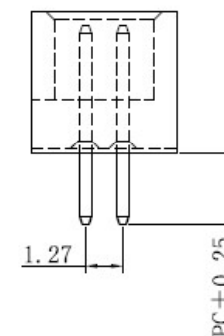
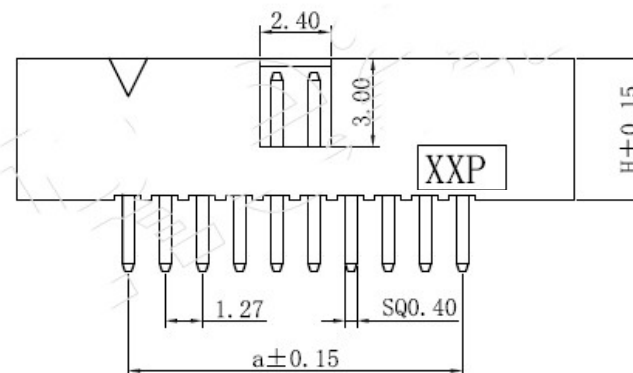

Ordering Information

BH1.27×H-K-nP-Gxx-Pxx-Mx

Insulator Height
H=4.9mm

Insulator Width
K=5.0mm

No. of Pins per Row
 6P 16P 30P 60P
 8P 18P 34P 64P
 10P 20P 40P 68P
 12P 24P 44P 70P
 14P 26P 50P
 D: DIP

Material Type:

1:PBT 2:PA6T 3:PA9T 4:LCP

Packing

1:PE bag 2:Tube pack
 3:Tray pack
 4:Tape and reel with CAP
 5:Tape and reel with MYLAR
 6:Tape and reel with SUS304

Contact Plated

0:Tin 1:Gold flash
 2:Gold 1U" 3:Gold 1.5U"
 4:Gold 3U" 5:Gold 10U"



PCB Layout

客户料号

客户料号

参考数据

规格型号

BH1.27×4.9-__P	4.9	5.0	
BH1.27×4.9-20P	4.9	5.0	2.4
BH1.27×H-nP	H	K	PC

shotech Steffen Hofmann

PRODUCT NAME: Box Header VER: 03
 SPECIFICATION: BH1.27×4.9-nP

TOLERANCE
UNLESS
OTHERWISE
SPECIFIED

DWG NO.:

UNIT: mm

CHECKED BY:

DATE: 2015.4.7

ECN:

SCALE:

SHEET: 1/1

DRAWN BY:

Burning

