

Type Silicon Monolithic Integrated Circuit
Product Name Sound Generator for Cellular Phone
Product No. BU8793KN

APPLICATION NOTE

1. Description of pin functions	Page 2
2. Timing Specification	Page 3
3. CPU interface	Page 6
4. Description of the sequencer	Page 6
5. Description of the registers	Page 7
6. Melody data format	Page 15
7. Standby general operation	Page 19
8. Tone data table	Page 20
9. KEY data(KEY)	Page 22
10. ADPCM decoder	Page 27
11. Synchronous melody LED control	Page 27
12. Playtime control function	Page 28
13. [Design memo] CompactMIDI format processing flow	Page 29
14. [Design memo] Performance data control of FIFO empty	Page 32

Date JUN-22,2005	Specification
ROHM CO.,LTD.	Specification No. Ver.E

1. Description of pin functions

Pin No.	Symbol	Description of function	Attribute	Circuit type	Remarks
15,6	Test-out[1:0]	Output pin for LSI test.	Out	F	Open during operation
20	INT	Interrupt pin of this IC. "L" for active ("H" for active can also be set.) Active when one of bit2, 1 or 0 of address 0x03 is "1".	Out	D	
17	LED	Output pin for LED light timing	Out	D	
14	DVdd	Digital power supply pin	-	-	
16	DVss	Digital ground pin	-	-	
22,21 8,7	Test-in[3:0]	Input pin to set LSI test Connect it to DVdd pin.	In	A	Connect to DVdd during operation
28	ANOUT-R (R)	Analog output pin. The potential of this pin is approximately same as Vref when not playing. It is equal to Hi-z when it is reset, and to Vref when it is set to monophonic mode.	Ana	G	
1	VREF	AC (signal) ground pin Connect a 1 μ F by-pass capacitor between Vref and ground pin. When you use the differential output between ANOUT-L and ANOUT-Mono, we suggest that VREF pin open, take by-pass capacitor off, because it decrease noise from AVDD line.	Ana	C	
2	ANOUT-L (L/Mono)	Analog output pin. The potential of this pin is approximately the same as Vref when not playing. It is equal to Hi-z when it is reset. This pin outputs monophonic output when it is set to monophonic mode.	Ana	G	
3	AVss	Analog ground pin	-	-	
27	AVdd	Analog power supply pin	-	-	
5	ANOUT-Mono (Mono)	Analog output pin. The potential of this pin is approximately the same as Vref when not playing. It is equal to Hi-z when it is reset. This pin outputs monophonic sound. When set to monophonic mode, inverted signal of ANOUT-L terminal (Mono) is output.	Ana	G	
26,24	Test-mode[1:0]	Input pin to set LSI test Connect it to DVdd pin.	In	A	Connect to DVdd during operation
23	MCLK	System clock input pin Any frequency can be selected between 12.5MHz and 18MHz. The scale precision within this range is approximately 0.2%.	In	E	
9	SO	Data output pin for serial interface. When SEL input is "H", the potential of this pin is equal to Hi-z.	Out	F	
10	SI/O	Data input/output pin for serial interface.	In/Out	B	
12	SCLK	Clock input pin for serial interface	In	A	
13	SEL	Select input pin for serial interface. Set to "L" to activate.	In	A	
19	NRST	Reset input pin. Set to "L" to activate.	In	A	

* Use the chip with the same voltage of DVDD (digital power supply) and AVDD (analog power supply).

Date	Specification
ROHM CO.,LTD.	Specification No. Ver.E

2. Timing Specification

(unless otherwise noted, Ta = 25°C)

Parameter	Symbol	Rating			Unit	Remarks
		Min.	Typ.	Max.		
Serial interface format						
Character bit length	Ncha	16	-	-	bit	MSB first
Serial interface characteristics						
SCLK input frequency	FSCLK	-	-	MCLK	MHz	
SCLK duty	DSCLK	40	50	60	%	
SEL "H" pulse width	Tw	25	-	-	nS	
SCLK-SEL setup time	Tscss	25	-	-	nS	to falling edge of SCLK
Data setup time	Tsc	25	-	-	nS	to falling edge of SCLK
Data hold time	Thc	25	-	-	nS	to falling edge of SCLK

Serial interface timing chart

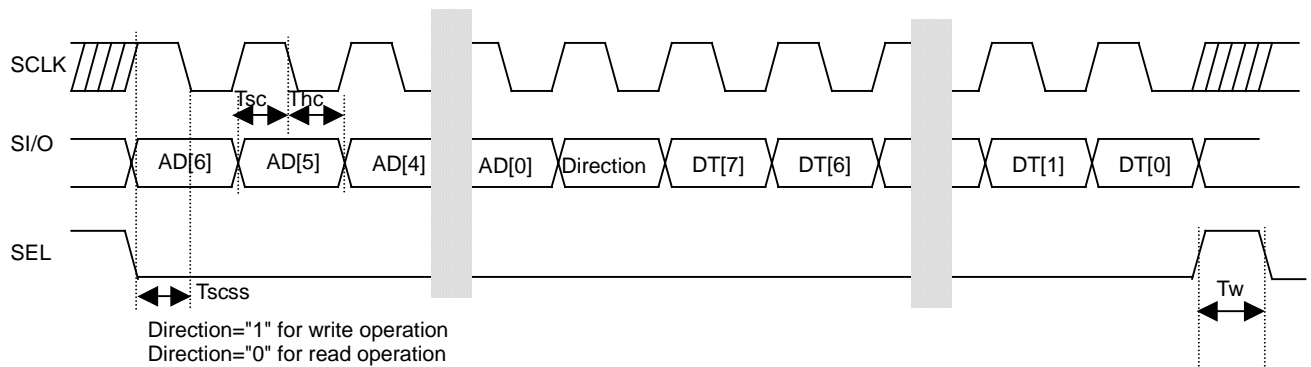

Write operation

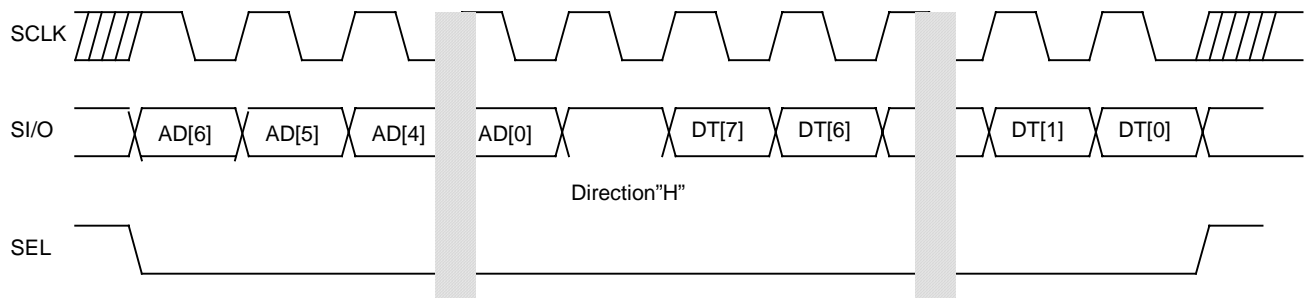

While SEL is held to "L", data (in 1 byte) can be written successively into a same address.

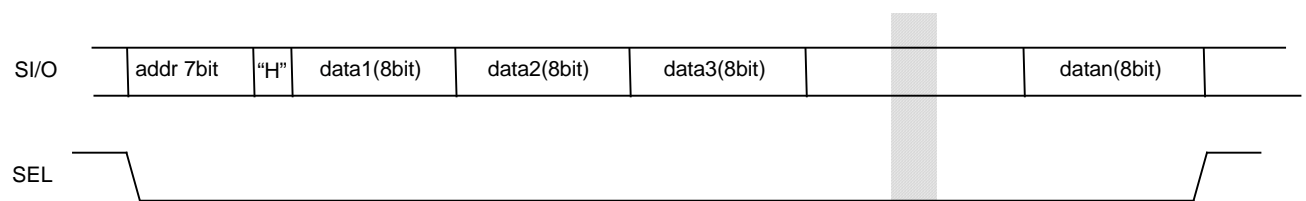

Date	Specification
ROHM CO.,LTD.	Specification No. Ver.E

Read operation (SI/O output): Output is synchronized to a falling edge of SCLK.
Output only when bit3 of address 0x00, Pmode = 0.

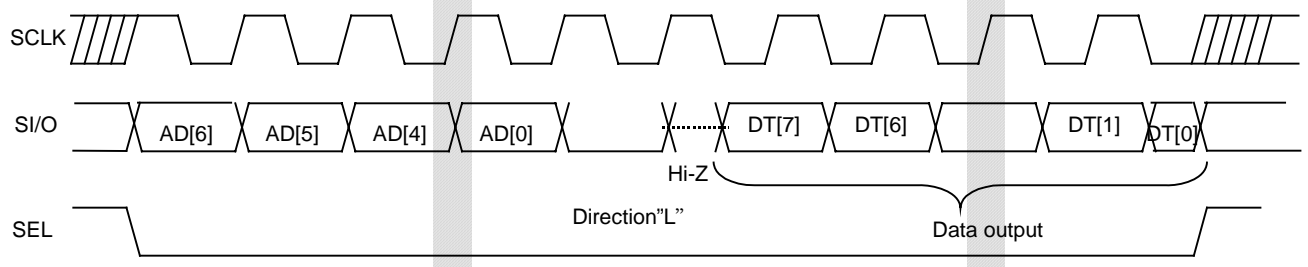

Read operation (SO output): Output is synchronized to a rising edge of SCLK.

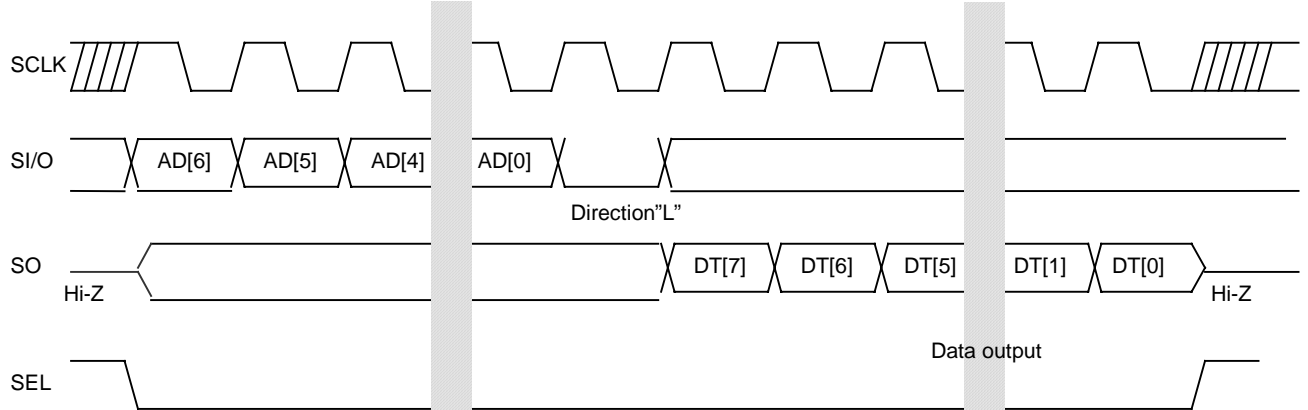

Date	Specification
ROHM CO.,LTD.	Specification No. Ver.E

Parameter	Symbol	Rating			Unit	Remarks
		Min.	Typ.	Max.		
Reset sequence						
VDD→NRST time	TRST	10	-	-	ms	
NRST→MCLK time	TCLK	0	-	-	ms	MCLK waveform must be normal.

<Pin reset sequence>

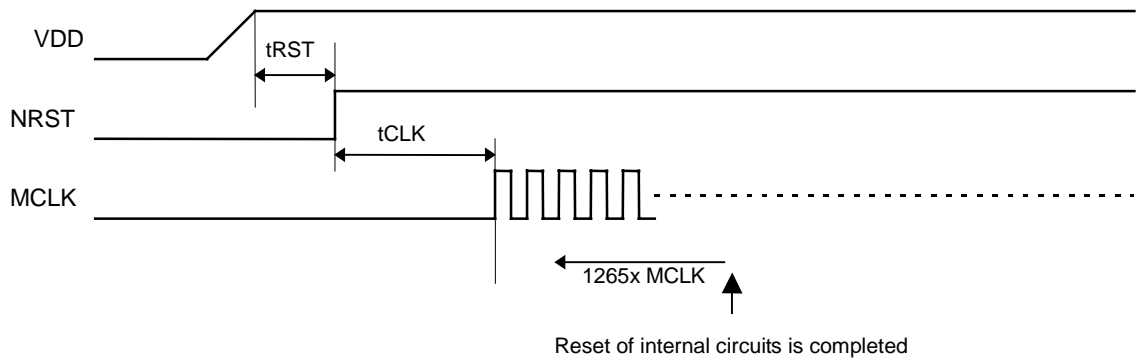

- * Be sure to reset the system after the power is turned on.
- * This sequence represents the external terminal, NRST.
This does not corresponds to the soft-reset (bit7 of register address 0x07).

Date	Specification
ROHM CO.,LTD.	Specification No. Ver.E

3. CPU interface

This IC has CPU interface of serial .

The interface signal is composed of 7-bit address, 1-bit direction, and 8-bit in/out data.

Write operation: The address, direction and data are fixed at the negative edge of SCLK.

Read operation: The address and direction are fixed at the negative edge of SCLK. The data are output from SO at the positive edge, and from SI/O at the negative edge. (Selected with bit 3 of address 0x00).

4. Description of the sequencer

This sequencer controls the timing of the sound sources according to the timing information in the melody data.

To take full advantage of the sound sources, it also has dynamic data assigning function to the sound sources.

These function allows high quality musical expressions.

[Outline of operation]

- 1) It fetches melody data stored in FIFO registers and assigns them to empty sound sources.
- 2) It sets the melody data into a WAVEgen Setup register to generate a tone.
- 3) It controls tone generation timing and turn the tone off at the tone end timing to release the sound sources.
- 4) It decides priority to assign the sound source according to the Track Number and the Voice Number.

If melody data with more than 16 tones are fetched, one of the tones played currently is deleted forcedly and a new tone is played. The tone to be deleted is decided according to Track Number and Voice Number. Since a tone with a lower Track Number and Voice Number has higher priority, assign a low Track Number or Voice Number to the important tones, such as main melody or drum set.

The algorithm to decide a tone to be deleted is as follows:

- ① A tone with highest Track Number is selected. If multiple tones are found,
- ② Among tones selected in step ①, a tone with highest Voice Number is selected. If multiple tones are found,
- ③ Among tones selected in step ②, a tone to which highest WAVEgen Number is assigned is selected.

The following shows the control data in the WAVEgen block.

This data is stored in the LSI and controlled by the Sequencer.

It can be accessed from the CPU via the Wave Window register.

SD[7:0]	Tone data
MD[6:0]	Scale data
PitchBend[9:0]	PitchBend sensibility (PitchBend[9]: ± directive bit)
LV[5:0]	Left channel volume data
RV[5:0]	Right channel volume data
Vib[6:0]	Vibrato parameter

Date	Specification
ROHM CO.,LTD.	Specification No. Ver.E

5. Description of the registers

The common control register can be controlled directly by the CPU.

The following table shows the register map.

Map of common control register for sound source

Address (Index)	Reg Name	R/W	Bit7	Bit6	Bit5	Bit4	Bit3	Bit2	Bit1	Bit0	
0x00	Common setup	W		SE		SFmode	Pmode	AN1/2	Mono	Tmute	
0x01	MIDI WAVE VOL	W	VOL7	VOL6	VOL5	VOL4	VOL3	VOL2	VOL1	VOL0	
0x02	ADPCM WAVE VOL	W	L/R	VOL6	VOL5	VOL4	VOL3	VOL2	VOL1	VOL0	
0x03	INT Status	R						MIDI INT	ADPCM INT	Timer INT	
	(INT Mask)	W	INTPol			LED Int Enb					
0x04	MIDI FIFO Status	R	Empty	NearEP	NearFL	LED	Ill Format	Empty Area	Full Area	BUSY	
	(Bit clear)	W	Clear	Clear	Clear	Clear	Clear	MIDI FIFO Clear		MIDI Sequence Start	
0x05	ADPCM FIFO Status	R	Empty	NearEP	NearFL			Empty Area	Full Area	BUSY	
	(Bit clear)	W	Clear	Clear	Clear			ADPCM FIFO Clear		ADPCM Start	
0x06	Timer Status	R							Call Back INT	Interval INT	
	(Bit clear)	W							Clear	Clear	
0x07	Sequ Control	W	Reset	Stand by	Anout Disable	Anout Mono Disable					
0x08	MIDI FIFO Control	W	Nearly Full setup				Nearly Empty setup				
0x09	ADPCM FIFO Control	W	Nearly Full setup				Nearly Empty setup				
0x0A	MIDI FIFO window	W	MIDI FIFO Data[7:0]								
0x0B	ADPCM FIFO window	W	ADPCM FIFO Data[7:0]								
0x0C	Time reg(1)	W	Time Setup data(1)								
0x0D	Time reg(2)	W	Time Setup data(2)								
0x0E	Interval Reg	W					Play Interval Time INT Value				
0x0F	Call Back Status	R	Call Back Message Status								
0x10	WaveSel	W					Wave Select[3:0]				
0x11	Wave Window	W	SD[7:0] tone								
0x12		W	MD[6:0] scale								
0x13		W						Pitch Bend[9:8]			
0x14		W	Pitch Bend[7:0]								
0x15		W			Lvol[5:0]						
0x16		W			Rvol[5:0]						
0x17		W	"0"	Vib[6:0]							

Date	Specification
ROHM CO.,LTD.	Specification No. Ver.E

0x18		W	Note on	Mute						
0x19	LED Control	W	LED ON							
0x1B	Reserved		Reserved (Don't use)							
0x1C	ADPCM rate	W	ADPCM rate[7:0]							
0x1D~0x7F	Reserved		Reserved (Don't use)							

Date	Specification
ROHM CO.,LTD.	Specification No. Ver.E

Address	0x00	Common Setup register	(Write only)
Bit6:	SE	SE mode	"L"-The sequencer uses Wave.gen[15:0]. (default) "H"-The sequencer uses Wave.gen[15.8]. Wave.gen[7:0] can be accessed directly by the CPU. # These bits must not be changed when the sequencer is operating.
Bit4:	Sfmode	ADPCM sampling rate	"H" write operation sets ADPCM sampling rate to 4kHz. "L" write operation sets ADPCM sampling rate to 8kHz. (default)
Bit3:	Pmode	Port mode selection	"H" write operation sets SI/O pin is input only. "L" write operation sets SI/O pin is in/out pin. (default)
Bit2:	AN1/2	Data format selection	"H" write operation sets the input data format to B. "L" write operation sets the input data format to A. (default) [For detailed description of the format, see the next chapter.] # When playing by the CPU directly without the sequencer, set this bit to "H" too.
Bit1:	Mono	Monophonic setting bit	"H" write operation sets the output to monophonic. "L" write operation sets the output to stereo. (default) In monophonic mode, ANOUT(L) is set to monophonic output and ANOUT(R) to muting condition.
Bit0:	Tmute	Forced muting of all the sound sources	"H" write operation sets the melody sound to mute and ADPCM sound conclude. "L" write operation clears the melody sound to mute. (default)
Address	0x01	MIDI Wave Vol register	(Write only)
Bit[7:0]:	VOL[7:0]	Melody volume	The analog output amplitude is proportional to the value set in this register. When set to 0x00, mute condition. Default=0x00 The max amplitude that one sound source makes (MIDI-WAVE-VOL-[7:0]=255, sound source inside[5:0]=63) is set to 0[db]. And when VOL changes, the amplitude is set to $20\log_{10}[\text{db}]$ (MIDI-WAVE-VOL[7:0]x sound source RVOL[5:0]/256x64). (In case of R-ch) In case of using several sound sources, the output amplitude of MIDI is the total of each amplitude of the sound sources. The max of each sound sources depends on musical instruments.
Address	0x02	ADPCM Wave Vol register	(Write only)
Bit7:	ADPCM volume (L/R)		Set to "L" to write the left volume, "H" to write the right volume.
Bit[6:0]:	VOL[6:0]	ADPCM volume	The analog output amplitude is proportional to the value set in this register. When set to 0x00, mute condition. Default=0x00 The max amplitude that ADPCM makes(ADPCM-VOL[6:0]=127) is set to 0[db]. When ADPCM-VOL changes the amplitude is set to $20\log_{10}[\text{db}]$ (ADPCM-VOL[6:0]/128). (In case of R-ch) And the output amplitude of the IC is the amplitude of MIDI+ADPCM.
Address	0x03	INT Status/Mask register	(Read/Write)
[Read operation]			
Bit2:	MIDI INT		"H" indicates presence of interrupt source in 0x04 (MIDI FIFO Status).
Bit1:	ADPCM INT		"H" indicates presence of interrupt source in 0x05 (ADPCM FIFO Status).
Bit0:	Timer INT		"H" indicates presence of interrupt source in 0x06 (Timer Status).
[Write operation]			
Bit7:	INT Polarity	Polarity of interrupt	"H" writing operation sets INT enable condition to "H". "L" writing operation sets INT enable condition to "L". (default)
Bit4:	LED Int Enb	Enable LED interrupt	"H" write operation enables LED interrupt. "L" write operation disables LED interrupt. (default)

Date	Specification
ROHM CO.,LTD.	Specification No. Ver.E

Address 0x04	MIDI FIFO Status/Bit Clear register	(Read/Write)
Bit7:	Empty FIFO Empty bit	(Interrupt source)
	<p>"H" indicates that sound source FIFO is empty. This bit is set to "H" when the FIFO condition is changed from 'not Empty' to 'Empty'. As the music is interrupted, the play intended by the composer can not be assured.</p> <p>Interrupt process of this bit:</p> <p>(1) When bit3 of this address, IllFormat, is "H", IllFormat interrupt is processed at first.</p> <p>(2) If melody data are transferred completely, the music stops when bit0 of this address, BUSY, is set to "L".</p> <p>(3) When playing music, data are written in the FIFO (it is preferable that the FIFO is written to nearly full).</p> <p>(4) This bit is cleared.</p>	
Bit6:	Nearly Empty FIFO Nearly Empty bit	(Interrupt source)
	<p>"H" indicates that remaining data size in sound source FIFO has reached to the value set in MIDI FIFO control register (address 0x08). This bit is set to "H" when the FIFO condition is changed from 'not Nearly Empty' to 'Nearly Empty'.</p> <p>Interrupt process of this bit:</p> <p>(1) This bit is cleared.</p> <p>(2) As the FIFO is nearly empty, data are written in the FIFO (it is preferable that the FIFO is written to nearly full).</p>	
Bit5:	Nearly Full FIFO Nearly Full bit	(Interrupt source)
	<p>"H" indicates that remaining data size in sound source FIFO reaches to the value set in MIDI FIFO control register (address 0x08). This bit is set to "H" when the FIFO condition is changed from 'not Nearly Full' to 'Nearly Full'.</p> <p>Interrupt process of this bit:</p> <p>(1) This bit is cleared.</p> <p>(2) As the FIFO is nearly full, writing data to the FIFO is stopped.</p>	
Bit4:	LED LED bit	(Interrupt source)
	<p>"H" indicates that a tone of Track No.0 and Voice No.0 is generated while playing music.</p> <p>Interrupt process of this bit:</p> <p>(1) This bit is cleared.</p> <p>(2) When interrupt occurs, LED output is set to "H".</p> <p>LED output is set to "L" by writing "L" in bit8 of address 0x19.</p>	
Bit3:	IllFormat Illegal Format bit	
	<p>"H" indicates that Empty is detected in playing data format.</p> <p>"H" causes abnormal sequencer stop and it can be started by sending music data again.</p> <p>Interrupt process of this bit:</p> <p>(1) This bit is cleared. The FIFO is set to Empty.</p> <p>(2) Return to the process of FIFO Empty (bit7 of this address).</p> <p>When writing data in the FIFO, be sure to write data from the top of the format.</p>	
Bit2:	Empty Area Empty area	
	<p>"H" indicates that pointer of the remaining music data is in Nearly Empty area.</p>	
Bit1:	Full Area Full area	
	<p>"H" indicates that pointer of the remaining music data is in Nearly Full area.</p>	
Bit0:	BUSY Busy bit	
	<p>"H" indicates that the music is playing or the sequencer is operating.</p> <p>This bit is set to "L" when the tone is stopped by setting sequencer start bit (bit0 of 0x04) to "L", or by FIFOempty or Tmute.</p>	

Date	Specification
ROHM CO.,LTD.	Specification No. Ver.E

[Write]

- Bit7: Empty Clear Writing "1" clears the Empty bit.
- Bit6: Nearly Empty Clear Writing "1" clears the Nearly Empty bit.
- Bit5: Nearly Full Clear Writing "1" clears the Nearly Full bit.
- Bit4: LED Clear Writing "1" clears the LED bit.
- Bit3: IllFormat Clear Writing "1" clears the Illegal Format bit.
Don't write "1" except when Illegal Format bit is "H".
- Bit2: MIDI FIFO Clear Writing "H" initializes MIDI FIFO register.
If this bit is changed in playing, the melody can not be assured.
- Bit0: MIDI Sequencer Start Sequencer start bit Writing "H" starts the sequencer.
Writing "L" stops the sequencer.
When writing "H" in Bit[7] Reset, this bit must be "L".
If this bit is changed while playing, the melody sound is stop.

Address 0x05 ADPCM FIFO Status/Bit Clear register (Read/Write)

[Read]

- Bit7: Empty FIFO Empty bit **(Interrupt source)**
"H" indicates that ADPCM FIFO is Empty. This bit is set to "H" when the FIFO condition is changed from 'not Empty' to 'Empty'.
Interrupt process of this bit:
(1) This bit is cleared.
(2) When bit0 of this address, BUSY, is changed to "L", the music stops.
When the FIFO is Empty, ADPCM accept no additional data.
(3) Write "L" in bit0 of this address, ADPCM Start.
- Bit6: Nearly Empty FIFO Nearly Empty bit **(Interrupt source)**
"H" indicates that remaining data size in ADPCM FIFO reaches to the value set in ADPCM FIFO control register (address 0x09). This bit is set to "H" when the FIFO condition is changed from 'not Nearly Empty' to 'Nearly Empty'.
Interrupt process of this bit:
(1) This bit is cleared.
(2) As the FIFO is nearly empty, data are written in the FIFO (it is preferable that the FIFO is written to nearly full).
- Bit5: Nearly Full FIFO Nearly Full bit **(Interrupt source)**
"H" indicates that remaining data size in ADPCM FIFO reaches to the value set in ADPCM FIFO control register (address 0x09). This bit is set to "H" when the FIFO condition is changed from 'not Nearly Full' to 'Nearly Full'.
Interrupt process of this bit:
(1) This bit is cleared.
(2) As the FIFO is nearly full, writing data in the FIFO is stopped.
- Bit2: Empty Area Empty area
"H" indicates that pointer of the remaining music data is in Nearly Empty area.
- Bit1: Full Area Full area
"H" indicates that pointer of the remaining music data is in Nearly Full area.
- Bit0: BUSY Busy bit
"H" indicates that ADPCM is playing.
This bit is set to "L" when the tone is stopped by FIFOempty or Tmute.
When 8 bytes of FIFO data is 0x00 successively, it is judged to be abnormal data, the music is stopped and this bit is set to "L".

Date	Specification
ROHM CO.,LTD.	Specification No. Ver.E

[Write]

- Bit7: Empty Clear Writing "1" clears the Empty bit.
- Bit6: Nearly Empty Clear Writing "1" clears the Nearly Empty bit.
- Bit5: Nearly Full Clear Writing "1" clears the Nearly Full bit.
- Bit2: ADPCM FIFO Clear Writing "H" initializes ADPCM FIFO register.
If this bit is changed while playing, the melody can not be assured.
- Bit0: ADPCM Start Writing "H" starts ADPCM play.
Music is not stopped until the FIFO is empty or "1" is written in Tmute (bit0 of address 0x00).

Address 0x06 Timer Status/Bit Clear register (Read/Write)

[Read]

- Bit1: Call Back INT **(Interrupt source)**
"H" indicates that the sequencer detects "Call Back Message".(show page24)
Interrupt process of this bit:
(1) This bit is cleared.
(2) 'Call Back Message Status' in address 0x0F is read
- Bit0: Interval INT **(Interrupt source)**
"H" indicates that an interrupt has occurred with an interval of "Play Interval Time INT Value".
Interrupt process of this bit:
(1) This bit is cleared.

[Write]

- Bit1: Call Back INT Clear Writing "1" clears the Call Back INT bit.
- Bit0: Interval INT Clear Writing "1" clears the Interval INT bit.

Address 0x07 Sequence Control register (Write only)

- Bit7: Reset Firmware reset "H" write operation initializes the sequencer and nearby circuits.
After writing "H", this bit is automatically set to "L" internally.
After writing "H", the following CPU can be accessed instantly.
Reset range: Sequencer, FIFO, Wave.gen, and Address 0x04,0x05,0x06 register.
The register not specified above holds the original value.
When playing a melody stops, set this bit to "H".
- Bit6: Standby Standby mode "H" write operation sets the IC to standby mode.
"L" write operation cancels the standby mode.
If this bit is changed while playing, the melody can not be assured.
- Bit5: Anout Dis Anout Disable bit "H" write operation sets Anout (L/R/Mono) to Hi-z.
"L" write operation sets Anout (L/R/Mono) to output. (default)
If this bit is changed while playing, the melody can not be assured.
- Bit4: Anout Mono Dis Anout Mono Disable bit "H" write operation sets Anout (Mono) to Hi-z.
"L" write operation sets Anout (Mono) to output. (default)
If this bit is changed while playing, the melody can not be assured.

Address 0x08 MIDI FIFO Control register (Write only)

- Bit[7:4] Nearly Full Setup When the remaining space size in MIDI FIFO reaches to the value set in these bits, 'Nearly Full' (bit5 of address 0x04) is set to "H".
"1000" - Remaining space is set to 1/16 of FIFO capacity.
"0100" - Remaining space is set to 1/8 of FIFO capacity. (default)
"0010" - Remaining space is set to 1/4 of FIFO capacity.
"0001" - Remaining space is set to 1/2 of FIFO capacity.
Others - Do not use!!

Date	Specification
ROHM CO.,LTD.	Specification No. Ver.E

Bit[3:0] Nearly Empty Setup When the remaining data size in MIDI FIFO reaches to the value set in these bits, 'Nearly Empty' (bit6 of address 0x04) is set to "H".

"1000" - Remaining data size is set to 1/16 of FIFO capacity.

"0100" - Remaining data size is set to 1/8 of FIFO capacity. (default)

"0010" - Remaining data size is set to 1/4 of FIFO capacity.

"0001" - Remaining data size is set to 1/2 of FIFO capacity.

Others - Do not use!!

Address 0x09 ADPCM FIFO Control register (Write only)

Bit[7:4] Nearly Full Setup When the remaining space size in ADPCM FIFO reaches to the value set in these bits 'Nearly Full' (bit5 of address 0x05) is set to "H".

"1000" - Remaining space is set to 1/16 of FIFO capacity.

"0100" - Remaining space is set to 1/8 of FIFO capacity. (default)

"0010" - Remaining space is set to 1/4 of FIFO capacity.

"0001" - Remaining space is set to 1/2 of FIFO capacity.

Others - Do not use!!

Bit[3:0] Nearly Empty Setup When the remaining data size in ADPCM FIFO reaches to the value set in these bits, 'Nearly Empty' (bit6 of address 0x05) is set to "H".

"1000" - Remaining data size is set to 1/16 of FIFO capacity.

"0100" - Remaining data size is set to 1/8 of FIFO capacity. (default)

"0010" - Remaining data size is set to 1/4 of FIFO capacity.

"0001" - Remaining data size is set to 1/2 of FIFO capacity.

Others - Do not use!!

Address 0x0A MIDI FIFO Window register (Write only)

Bit[7:0] MID FIFO Window Melody data FIFO window

Data written in this register are stored in the sound source FIFO.

After writing, the write pointer is incremented.

Address 0x0B ADPCM FIFO Window register (Write only)

Bit[7:0] ADPCM FIFO Window Melody data FIFO window

Data written in this register are stored in the ADPCM FIFO.

After writing, the write pointer is incremented.

Address 0x0C Time setup register (1) (Write only)

Bit[7:0] time setup

Set a frequency dividing ratio to prepare 128 kHz required for the sound source from MCLK.

For 13 MHz of MCLK, set the register to 0x66.(default)

For 14 MHz of MCLK, set the register to 0x6D.

For 16 MHz of MCLK, set the register to 0x7D.

For 18 MHz of MCLK, set the register to 0x8D.

Calculation: The register is set to MCLK/128 kHz

Address 0x0D Time setup register (2) (Write only)

Bit[7:0] time setup

Set a frequency dividing ratio to prepare 44.1 kHz required for the sound source from MCLK.

For 13 MHz of MCLK, set the register to 0x27.(default)

For 14 MHz of MCLK, set the register to 0x3D.

For 16 MHz of MCLK, set the register to 0x6B.

For 18 MHz of MCLK, set the register to 0x98.

Calculation: The register is set to MCLK/(22.05 kHz x 2)

For 12.5 MHz - 18 MHz of MCLK, setting of 9th bit is not required as it is always fixed to "1".

Only lower 8 bits are to be set.

Date	Specification
ROHM CO.,LTD.	Specification No. Ver.E

Address 0x0E Interval Timer Interrupt (Write)
 Bit[3:0] Play Time Interval Value During the MIDI Sequencer Start (Address 0x04 bit0) = '1', time is counted, and interrupts occur with the timing specified in this register.
 "0000" - No interrupt in play time. (default)
 "0001" - Interrupt occurs every 5 ms.
 "001x" - Interrupt occurs every 10 ms.
 "01xx" - Interrupt occurs every 50 ms.
 "1xxx" - Interrupt occurs every 100 ms.

Address 0x0F Call Back Message Status (Read only)
 Bit[7:0] Call Back Message Status Indicates status of the current message.
 Maintain that until next one received.

For Call Back Message, see Play Data Format in the next chapter.

Address 0x10 Wave Select register (Write)
 Bit[4:0] Wave Select "0000" - Wave.gen 0 is selected. (default)
 "0001" - Wave.gen 1 is selected.
 "0010" - Wave.gen 2 is selected.
 "0011" - Wave.gen 3 is selected.
 : :
 "1101" - Wave.gen 13 is selected.
 "1110" - Wave.gen 14 is selected.
 "1111" - Wave.gen 15 is selected.

Address 0x11~0x18 Wave.gen register (Read/Write)
 These register directly accesses the sound source internal register (SRAM).
 To write PitchBend, write in order of 0x13 and 0x14.

Address 0x19 LED Control register (Write only)
 Bit[7] LED ON Write "H" in this bit to set LED output terminal to "H".
 When LEDIntEnb (bit4 of address 0x03) is "H", LED output is set by OR signal with LEDON by the sequencer.
 Write "L" in this bit to set LED output terminal to "L".

Address 0x1C ADPCM rate register (Write only)
 Bit[7:0] ADPCM rate Set a frequency dividing ratio to prepare 24 kHz required for the ADPCM from MCLK.
 For 13 MHz of MCLK, set the register to 0x1E..(default)
 For 14 MHz of MCLK, set the register to 0x47.
 For 16 MHz of MCLK, set the register to 0x9B.
 For 18 MHz of MCLK, set the register to 0xEE.
 Calculation: The register is set to MCLK/24 kHz
 For 12.5 MHz - 18 MHz of MCLK, setting of 10th and 9th bit is not required as these are always fixed to "10". Only lower 8 bits are to be set.

Address 0x0A~0x0B,0x1D~0x7F Reserved for future use. Do not access these addresses.

Date	Specification
ROHM CO.,LTD.	Specification No. Ver.E

6. Melody data format

The CPU indicates the format of the data stored in RAM (FIFO).

Select from either of two data formats.

Select whether to use AN1 or AN2 bit.

[Format A] In this format, note-off time is calculated and controlled from tone length data with the sequencer. Therefore, no note-off message is required.

Note message format (7 bytes)

Bit7	Bit6	Bit5	Bit4	Bit3	Bit2	Bit1	Bit0
Delta Time							
Track Number 0 - 255							
Voice Number				Key[5:0]			
Tone (Expansion code *Length of 6 Bytes)							
		Key[6]		L-Volume			
Mute		Extension		R-Volume			
Length of sound [Gate Time] Unit: Delta Time							

[Format B] In this format, note-on/off is controlled with note-on messages and note-off messages.

Note on message format (6 bytes)

Bit7	Bit6	Bit5	Bit4	Bit3	Bit2	Bit1	Bit0
Delta Time							
Track Number 0 - 63						Voice Number	
ToneON	Key[6:0]						
Tone (Expansion code)							
-		L-Volume					
Mute		-		R-Volume			

Note on message format (3 bytes)

Bit7	Bit6	Bit5	Bit4	Bit3	Bit2	Bit1	Bit0
Delta Time							
Track Number 0 - 63						Voice Number	
/ToneOFF	Key[6:0]						

Description of format

Delta Time (Common to format A and B)

: Each setting in the Δ time register is called 1 Δ time, which indicates the amount of time that has elapsed since the previous event.

Track Number (Common to format A and B)

: Indicates the sequence in which tracks are played (0, 1, 2, etc.)

Voice Number (Common to format A and B)

: Indicates voice number in current track.

Key[6:0] (Common to format A and B)

: Indicates the key (scale) of sounds being generated. [Refer to "5. Key data" for the details (page30/41).]

Tone (Common to format A and B)

:0x00~0xF9 make to indicate the tone of the sound source.

0xFA~0xFF make an expansion code.

Expansion code is 6 bytes in length.

Date	Specification
ROHM CO.,LTD.	Specification No. Ver.E

L-Volume (Common to format A and B)

:Volume of left channel. The amplitude of analog output is proportional to this value.

R-Volume (Common to format A and B)

: Volume of right channel. The amplitude of analog output is proportional to this value.

Mute (Common to format A and B)

: Mute setting Specified tone is noted-off, then muted.

Tone On/Off (Format B only)

: Tone ON/OFF control 1: Tone on or expansion code
0: Tone off

Sound length (Format A only)

: Indicates the length of a generated sound. This is expressed as the Δ time.
When sound length is 0xFF, it is based on the extension of the sound length being done in the rest, and pronunciation at this time is protected [any case], too.

Extension (Format A only)

: 0: NOP
1: It is shown that the extension of the sound length is done in the rest.
The control which is equal to the time when sound head is 0xFF is done.

[Call Back message] (Common to format A and B)

Bit7	Bit6	Bit5	Bit4	Bit3	Bit2	Bit1	Bit0
Delta Time							
0x00							
0x80							
0xFA							
0x00							
Status							

When this message is received, an interruption occurs.

The status of this message is expressed in the register address 0x0F.

[Pitch Bend message] (Common to format A and B)

Bit7	Bit6	Bit5	Bit4	Bit3	Bit2	Bit1	Bit0
Delta Time							
Identical to 2nd byte of format A or B respectively							
Identical to 3rd byte of format A or B respectively							
0xFB							
—	Key[6>(*1)	—				+/-	Shift[8]
Shift[7:0]							

This message makes the settings for performing Pitch Bend.

The bit [1] of the upper byte is assigned to the polarity +/- and sets the shift for the KEY at Note On.

1LSB is 100/32[sent], and 10 bits are effective. The range is +/-1596[sent].

When this message (Pitchbend) and the Note On message targeted by this message occur at the same time (where Delta Time = 0), write the Note On message first and then the Pitchbend message into the FIFO. The sequencer disregards the Pitchbend message if it receives the Pitchbend message without the targeted Note ON message.

*1: In the format A, set Key[6] to Bit6.

Date	Specification
ROHM CO.,LTD.	Specification No. Ver.E

+/- shift [9]	Shift [8:0]	
1	0-0000-0000	-(512 * 100 / 32) [sent]
...
1	1-1111-1110	-(2 * 100 / 32) [sent]
1	1-1111-1111	-(1 * 100 / 32) [sent]
0	0-0000-0000	0 [sent]
0	0-0000-0001	(1 * 100 / 32) [sent]
0	0-0000-0010	(2 * 100 / 32) [sent]
..
0	1-1111-1111	(511 * 100 / 32) [sent]

[Vib message] (Common to format A and B)

Bit7	Bit6	Bit5	Bit4	Bit3	Bit2	Bit1	Bit0
Delta Time							
Identical to 2nd byte of format A or B respectively							
Identical to 3rd byte of format A or B respectively							
0xFC							
—	Key[6>(*1)					—	
"0"	Vib						

This message sets Vibrato to generated sounds.

This setting is effective from the time this message has just been received.

The original sound is assigned to Vib = "00000000", and the quantity of vibrato is adjusted in 128 steps of Vib[6:0] and Vib[7] is fixed "0"..

When this message (Vib) and the Note On message targeted by this message occur at the same time (where Delta Time = 0), write the Note On message first and then the Vib message into the FIFO. The sequencer disregards the Vib message if it receives the Vib message without the targeted Note ON message.

*1: In the format A, set Key[6] to Bit6.

[NOP message] (Common to format A and B)

Bit7	Bit6	Bit5	Bit4	Bit3	Bit2	Bit1	Bit0
Delta Time							
0x00							
0x80							
0xFD							
0x00							
0x00							

Message to specify no operation. This is used to adjust Delta Time.

For example, to start an event X when Delta Time = 500 is elapsed after a previous event.

After sending a NOP message, FF,00,80,FD,00,00, send format data of event X with Delta Time = 145

Date	Specification
ROHM CO.,LTD.	Specification No. Ver.E

[Δtime message] (Common to format A and B)

Bit7	Bit6	Bit5	Bit4	Bit3	Bit2	Bit1	Bit0
Delta Time							
0x00							
0x80							
0xFE							
Δ time (U)							
Δ time (L)							

Setting Δtime that was turned into be common in performance data.

Accordingly, Track Number and Voice No are disregarded.

The information of a performance data overall is made.

Integer9bits+decimal7bits, total 16bits with unit [ms].Range is 0.125 to 511 [ms].

The time below is assigned to each bit, and sum of these times is equal to Delta Time (in ms).

Δ time (U)							
256	128	64	32	16	8	4	2

Δ time (L)							
1	1/2	1/4	1/8	1/16	1/32	1/64	1/128

For example,when Delta Time is 10.25 ms, Δ time(U) = 0x05, Δ time(L) = 0x20.

[TimeBase message] (Format A only)

Bit7	Bit6	Bit5	Bit4	Bit3	Bit2	Bit1	Bit0
Delta Time							
Track Number 0~15							
0x00							
0xFF							
0x00							
TimeBase							

Whether each track is what times were shown with “Δtime message” is set up.

Accordingly, Voice number disregarded and the information of each track number is made.

Only the sound length of Format A (Gate Time) is controlled by this message.

Yet, only track0 to 15, “Time base” is handled as 110b in the track15 of after.

Appropriate sound length setting is required.

TimeBase[2:0]	000b = x64
	001b = x32
	010b = x16
	011b = x8
	100b = x4
	101b = x2
	110b = x1
	other = Don't use !!

For example, when Track0 Δ time=X and Track1 Δ time=4*X, set Δ time message above to 'Δ time=X'. In this case, Track1 will be processed in 1/4 Δ time of actual Δ time.

This message set TimeBase=110b(x1) for Track0 and TimeBase=100b(x4) for Track1. With this method, tone length of original data of both Track0 and Track1 are set directly in 7th byte of the note message format.

Date	Specification
ROHM CO.,LTD.	Specification No. Ver.E

7. Standby general operation

Address 0x07, Sequence Control register bit[6];

"1" write operation sets this IC to standby mode.

When standby mode:

MCLK(input) is gated. (MCLK can be in Hi-z condition.)

Analog block sleep.

All the control registers do not move (except address 0x07, Sequence Control register bit[6]).

Standby setting procedure

Standby when playing music

1. Write "H" in bit1 of address 0x00 (muting to avoid noise).
2. Write "L" in bit0 of address 0x04 (stop MIDI sequencer).
3. Write "H" in bit7 of address 0x07 (reset).
4. Write "H" in bit6 of address 0x07 (standby).

Then the IC is in standby mode and MCLK can be stopped.

Standby release procedure

1. Write "L" in bit6 of address 0x07 (standby release).
2. Activate MCLK, if stopped.
3. Write "H" in bit7 of address 0x07 (reset).

Then standby mode is released to allow playing music by setting registers.

Date	Specification
ROHM CO.,LTD.	Specification No. Ver.E

8. Tone data table

The tone data is shown below.

These correspond to the tones in the melody data format. (4th byte of format A and format B. Address is 0x11 for CPU direct.)

SD[7:0]	Instrument	SD[7:0]	Instrument	SD[7:0]	Instrument
0x00	Acoustic Grand Piano	0x30	String Ensembles 1	0x60	FX1(rain)
0x01	Bright Acoustic Piano	0x31	String Ensembles 2	0x61	FX2(soundtrack)
0x02	Electric Grand Piano	0x32	Synth Strings 1	0x62	FX3(crystal)
0x03	Honky-tonk Piano	0x33	Synth Strings 2	0x63	FX4(atmosphere)
0x04	Electric Piano 1	0x34	Choir Aahs	0x64	FX5(brightness)
0x05	Electric Piano 2	0x35	Voice Oohs	0x65	FX6(goblins)
0x06	Harpsichord	0x36	Synth Voice	0x66	FX7(echoes)
0x07	Clavi	0x37	Orchestra Hit	0x67	FX8(sci-fi)
0x08	Celesta	0x38	Trumpet	0x68	Sitar
0x09	Glockenspiel	0x39	Trombone	0x69	Banjo
0x0A	Music Box	0x3A	Tuba	0x6A	Shamisen
0x0B	Vibraphone	0x3B	Muted Trumpet	0x6B	Koto
0x0C	Marimba	0x3C	French Horn	0x6C	Kalimba
0x0D	Xylophone	0x3D	Brass Section	0x6D	Bagpipe
0x0E	Tubular Bells	0x3E	Synth Brass 1	0x6E	Fiddle
0x0F	Dulcimer	0x3F	Synth Brass 2	0x6F	Shanai
0x10	Drawbar Organ	0x40	Soprano Sax	0x70	Tinkle Bell
0x11	Percussive Organ	0x41	Alto Sax	0x71	Agogo
0x12	Rock Organ	0x42	Tenor Sax	0x72	Steel Drum
0x13	Church Organ	0x43	Baritone Sax	0x73	Woodblock
0x14	Reed Organ	0x44	Oboe	0x74	Taiko Drum
0x15	Accordion	0x45	English Horn	0x75	Melodic Tom
0x16	Harmonica	0x46	Bassoon	0x76	Synth Drum
0x17	Tango Accordion	0x47	Clarinet	0x77	Reverse Cymbal
0x18	Acoustic Guitar (nylon)	0x48	Piccolo	0x78	Guitar Fret Noise
0x19	Acoustic Guitar (steel)	0x49	Flute	0x79	Breath Noise
0x1A	Electric Guitar (jazz)	0x4A	Recorder	0x7A	Seashore
0x1B	Electric Guitar (clean)	0x4B	Pan Flute	0x7B	Bird Tweet
0x1C	Electric Guitar (muted)	0x4C	Blow Bottle	0x7C	Telephone Ring
0x1D	Overdrive Guitar	0x4D	Shakuhachi	0x7D	Helicopter
0x1E	Distortion Guitar	0x4E	Whistle	0x7E	Applause
0x1F	Guitar Harmonics	0x4F	Ocarina	0x7F	Gun Shot
0x20	Acoustic Bass	0x50	Lead1(square)		
0x21	Electric Bass (finger)	0x51	Lead2(sawtooth)		
0x22	Electric Bass (pick)	0x52	Lead3(calliope)		
0x23	Fretless Bass	0x53	Lead4(chiff)		
0x24	Slap Bass 1	0x54	Lead5(charang)		
0x25	Slap Bass 2	0x55	Lead6(voice)		
0x26	Synth Bass 1	0x56	Lead7(fifths)		
0x27	Synth Bass 2	0x57	Lead8(bass+lead)		
0x28	Violin	0x58	Pad1(new age)		
0x29	Viola	0x59	Pad2(warm)		
0x2A	Cello	0x5A	Pad3(polysynth)		
0x2B	Contrabass	0x5B	Pad4(choir)		
0x2C	Tremolo Strings	0x5C	Pad5(bowed)		
0x2D	Pizzicato Strings	0x5D	Pad6(metallic)		
0x2E	Orchestral Harp	0x5E	Pad7(halo)		
0x2F	Timpani	0x5F	Pad8(sweep)		

Date	Specification
ROHM CO.,LTD.	Specification No. Ver.E

SD[7:0]	Instrument	SD[7:0]	Instrument	SD[7:0]	Instrument
0x80	Acoustic Bass Drum	0xB0	Cursor move sound (Long)	0xE0	Special rectangle (no ENV)
0x81	Bass Drum	0xB1	Beep (Normal)	0xE1	Sin (1.6s)
0x82	Side Stick	0xB2	Beep (Outer space)	0xE2	Sin (0.8s)
0x83	Acoustic Snare	0xB3	Siren 1	0xE3	Sin (no ENV)
0x84	Hand Clap	0xB4	Character power up	0xE4	Reserved
0x85	Electric Snare	0xB5	Character get	0xE5	Reserved
0x86	Low Floor Tom	0xB6	Up	0xE6	Reserved
0x87	Closed Hi-hat	0xB7	Down	0xE7	Reserved
0x88	High Floor Tom	0xB8	Luffin	0xE8	Reserved
0x89	Pedal Hi-hat	0xB9	Scream	0xE9	Reserved
0x8A	Low Tom	0xBA	Pretty	0xEA	Reserved
0x8B	Open Hi-hat	0xBB	Mystery	0xEB	Reserved
0x8C	Low Mid Tom	0xBC	Robot	0xEC	Reserved
0x8D	High Mid Tom	0xBD	Foot step	0xED	Reserved
0x8E	Crash Cymbal1	0xBE	Character rotation	0xEE	Reserved
0x8F	High Tom	0xBF	Character jump	0xEF	Reserved
0x90	Ride Cymbal 1	0xC0	Laser gun (Short)	0xF0	Reserved
0x91	Chinese Cymbal	0xC1	Hit1 (hard)	0xF1	Reserved
0x92	Ride Bell	0xC2	Hit2 (noise)	0xF2	Reserved
0x93	Tambourine	0xC3	Bomb (Short)	0xF3	Reserved
0x94	Splash Cymbal	0xC4	Bomb (Long)	0xF4	Reserved
0x95	Cowbell	0xC5	Monster damage	0xF5	Reserved
0x96	Crash Cymbal2	0xC6	Robot damage	0xF6	Reserved
0x97	Vibra-slap	0xC7	Character fade out	0xF7	Reserved
0x98	Ride Cymbal2	0xC8	Engine	0xF8	Reserved
0x99	High Bongo	0xC9	Approach (fade in)	0xF9	Reserved
0x9A	Low Bongo	0xCA	Take off (fade out)	0xFA	Reserved
0x9B	Mute Hi Conga	0xCB	Space (filter drown)	0xFB	Reserved
0x9C	Open Hi Conga	0xCC	Science (Hi drown)	0xFC	Reserved
0x9D	Low Conga	0xCD	Bubble	0xFD	Reserved
0x9E	High Timbale	0xCE	Drop	0xFE	Reserved
0x9F	Low Timbale	0xCF	Reserved	0xFF	Reserved
0xA0	High Agogo	0xD0	Reserved		
0xA1	Low Agogo	0xD1	Reserved		
0xA2	Cabasa	0xD2	Reserved		
0xA3	Maracas	0xD3	Reserved		
0xA4	Short Whistle	0xD4	Reserved		
0xA5	Long Whistle	0xD5	Reserved		
0xA6	Short Guiro	0xD6	Reserved		
0xA7	Long Guiro	0xD7	Reserved		
0xA8	Claves	0xD8	Reserved		
0xA9	Hi Wood Block	0xD9	Reserved		
0xAA	Low Wood Block	0xDA	Reserved		
0xAB	Mute Cuica	0xDB	Reserved		
0xAC	Open Cuica	0xDC	Reserved		
0xAD	Mute Triangle	0xDD	Reserved		
0xAE	Open Triangle	0xDE	Special rectangle (1.6s)		
0xAF	Cursor move sound (Short)	0xDF	Special rectangle (0.8s)		

Note) The following assignments set Compact MIDI format compatibility for the above tones.

Tone bank 2 & tone data 0 to 63 are assigned to 0x00 to 0x3F in SD [7:0].

Tone bank 3 & tone data 0 to 63 are assigned to 0x40 to 0x7F in SD [7:0].

Tone bank 52 & tone data 0 to 31 are assigned to 0xAF to 0xCE in SD [7:0].

Tone bank 62 & tone data 0 & Key data 0 to 46 are assigned to 0x80 to 0xAE in SD [7:0].

Date	Specification
ROHM CO.,LTD.	Specification No. Ver.E

9. KEY data (KEY)

The KEY data table is shown below.

These correspond to the KEY in the melody data format.

Melody data format Key[6:0]	Real KEY	Remarks *MIDI	Remark	*CompactMIDI
			OCTSFT	KEY
0	A[27.5Hz]	21	-2	0
1	A#	22		1
~	~	~		~
61		82		61
62		83		62
12	A[55Hz]	33	-1	0
13	A#	34		1
~	~	~		~
73		94		61
74		95		62
24	A[110Hz]	45	0	0
25	A#	46		1
~	~	~		~
85		106		61
86		107		62
36	A[220Hz]	57	1	0
37	A#	58		1
~	~	~		~
97		118		61
98		119		62

[The pronunciation area of the endorse toward each timbre]

Use a key value between KEY lower and upper limits of BU8793KN in this table.

NO.	Instrument	The pronunciation area of the endorse									
		MIDI key		BU8772 Key		Compact MIDI Key					
		KEY lower limit	KEY upper limit	KEY lower limit	KEY upper limit	KEY lower limit			KEY upper limit		
						OCTSFT	KEY	Hex	OCTSFT	KEY	Hex
0	Acoustic Grand Piano	21	95	0	74	-2	0	80	0	50	32
1	Bright Acoustic Piano	21	95	0	74	-2	0	80	0	50	32
2	Electric Grand Piano	21	95	0	74	-2	0	80	0	50	32
3	Honkey-tonk Piano	21	95	0	74	-2	0	80	0	50	32
4	Electric Piano1	28	95	7	74	-2	7	87	0	50	32
5	Electric Piano2	28	95	7	74	-2	7	87	0	50	32
6	Harpsichord	41	89	20	68	-1	8	C8	0	44	2C
7	Clavi	36	95	15	74	-1	3	C3	0	50	32
8	Celesta	60	95	39	74	0	15	F	0	50	32
9	Glockenspiel	72	83	51	62	0	27	1B	0	38	26
10	Music Box	60	84	39	63	0	15	F	0	39	27
11	Vibraphone	53	89	32	68	0	8	8	0	44	2C
12	Marimba	48	84	27	63	0	3	3	0	39	27
13	Xylophone	65	95	44	74	0	20	14	0	50	32
14	Tubular Bells	60	77	39	56	0	15	F	0	32	20
15	Dulcimer	60	84	39	63	0	15	F	0	39	27
16	Drawbar Organ	36	95	15	74	-1	3	C3	0	50	32
17	Percussive Organ	36	95	15	74	-1	3	C3	0	50	32
18	Rock Organ	36	95	15	74	-1	3	C3	0	50	32
19	Church Organ	21	95	0	74	-2	0	80	0	50	32
20	Reed Organ	36	83	15	62	-1	3	C3	0	38	26
21	Accordion	53	83	32	62	0	8	8	0	38	26
22	Harmonica	60	83	39	62	0	15	F	0	38	26
23	Tango Accordion	53	89	32	68	0	8	8	0	44	2C
24	Acoustic Guitar(nylon)	40	84	19	63	-1	7	C7	0	39	27
25	Acoustic Guitar(steel)	40	84	19	63	-1	7	C7	0	39	27

Date	Specification
ROHM CO.,LTD.	Specification No. Ver.E

26	Electric Guitar(jazz)	40	86	19	65	-1	7	C7	0	41	29
27	Electric Guitar(clean)	40	86	19	65	-1	7	C7	0	41	29
28	Electric Guitar(muted)	40	86	19	65	-1	7	C7	0	41	29
29	Overdriven Guitar	40	83	19	62	-1	7	C7	0	38	26
30	Distortion Guitar	40	86	19	65	-1	7	C7	0	41	29
31	Guitar harmonics	40	86	19	65	-1	7	C7	0	41	29
32	Acoustic Bass	28	55	7	34	-2	7	87	0	10	A
33	Electric Bass(finger)	28	55	7	34	-2	7	87	0	10	A
34	Electric Bass(pick)	28	55	7	34	-2	7	87	0	10	A
35	Fretless Bass	28	55	7	34	-2	7	87	0	10	A
36	Slap Bass1	28	55	7	34	-2	7	87	0	10	A
37	Slap Bass2	28	55	7	34	-2	7	87	0	10	A
38	Synth Bass1	28	55	7	34	-2	7	87	0	10	A
39	Synth Bass2	28	55	7	34	-2	7	87	0	10	A
40	Violin	55	95	34	74	0	10	A	0	50	32
41	Viola	48	84	27	63	0	3	3	0	39	27
42	Cello	36	72	15	51	-1	3	C3	0	27	1B
43	Contrabass	28	55	7	34	-2	7	87	0	10	A
44	Tremolo Strings	28	96	7	75	-2	7	87	0	51	33
45	Pizzicato Strings	28	96	7	75	-2	7	87	0	51	33
46	Orchestral Harp	23	103	2	82	-2	2	82	0	58	3A
47	Timpani	36	57	15	36	-1	3	C3	0	12	C
48	String Emsemble1	28	96	7	75	-2	7	87	0	51	33
49	String Emsemble2	28	96	7	75	-2	7	87	0	51	33
50	Synth String1	36	96	15	75	-1	3	C3	0	51	33
51	Synth String2	36	83	15	62	-1	3	C3	0	38	26
52	Choir Aahs	48	83	27	62	0	3	3	0	38	26
53	Voice Oohs	48	79	27	58	0	3	3	0	34	22
54	Synth Vox	48	84	27	63	0	3	3	0	39	27
55	Orchestra Hit	48	72	27	51	0	3	3	0	27	1B
56	Trumpet	58	94	37	73	0	13	D	0	49	31
57	Trombone	34	75	13	54	-1	1	C1	0	30	1E
58	Tuba	29	55	8	34	-2	8	88	0	10	A
59	Muted Trumpet	58	82	37	61	0	13	D	0	37	25
60	French Horn	41	77	20	56	-1	8	C8	0	32	20
61	Brass Section	36	77	15	56	-1	3	C3	0	32	20
62	Synth Brass1	36	83	15	62	-1	3	C3	0	38	26
63	Synth Brass2	36	95	15	74	-1	3	C3	0	50	32
64	Soprano Sax	54	87	33	66	0	9	9	0	42	2A
65	Alto Sax	49	80	28	59	0	4	4	0	35	23
66	Tenor Sax	42	75	21	54	-1	9	C9	0	30	1E
67	Baritone Sax	37	68	16	47	-1	4	C4	0	23	17
68	Oboe	58	83	37	62	0	13	D	0	38	26
69	English Horn	52	81	31	60	0	7	7	0	36	24
70	Bassoon	34	72	13	51	-1	1	C1	0	27	1B
71	Clarinet	50	83	29	62	0	5	5	0	38	26
72	Piccolo	74	95	53	74	0	29	1D	0	50	32
73	Flute	60	96	39	75	0	15	F	0	51	33
74	Recorder	60	96	39	75	0	15	F	0	51	33
75	Pan Flute	60	96	39	75	0	15	F	0	51	33
76	Blown Bottle	60	83	39	62	0	15	F	0	38	26
77	Shakuhachi	55	84	34	63	0	10	A	0	39	27
78	Whistle	60	96	39	75	0	15	F	0	51	33
79	Ocarina	60	84	39	63	0	15	F	0	39	27
80	Lead1(square)	21	95	0	74	-2	0	80	0	50	32
81	Lead2(sawtooth)	21	95	0	74	-2	0	80	0	50	32
82	Lead3(calliope)	48	96	27	75	0	3	3	0	51	33
83	Lead4(chiiff)	48	96	27	75	0	3	3	0	51	33
84	Lead5(charang)	48	91	27	70	0	3	3	0	46	2E
85	Lead6(voice)	48	84	27	63	0	3	3	0	39	27

Date	Specification
ROHM CO.,LTD.	Specification No. Ver.E

86	Lead7(fifths)	36	96	15	75	-1	3	C3	0	51	33
87	Lead8(bass + lead)	21	91	0	70	-2	0	80	0	46	2E
88	Pad1(new age)	36	96	15	75	-1	3	C3	0	51	33
89	Pad2(warm)	36	96	15	75	-1	3	C3	0	51	33
90	Pad3(polysynth)	36	96	15	75	-1	3	C3	0	51	33
91	Pad4(choir)	48	84	27	63	0	3	3	0	39	27
92	Pad5(bowed)	48	96	27	75	0	3	3	0	51	33
93	Pad6(metallic)	21	91	0	70	-2	0	80	0	46	2E
94	Pad7(halo)	36	96	15	75	-1	3	C3	0	51	33
95	Pad8(sweep)	36	96	15	75	-1	3	C3	0	51	33
96	Fx1(rain)	36	96	15	75	-1	3	C3	0	51	33
97	Fx2(soundtrack)	36	84	15	63	-1	3	C3	0	39	27
98	Fx3(crystal)	60	95	39	74	0	15	F	0	50	32
99	Fx4(atmosphere)	36	96	15	75	-1	3	C3	0	51	33
100	Fx5(brightness)	36	96	15	75	-1	3	C3	0	51	33
101	Fx6(goblins)	36	96	15	75	-1	3	C3	0	51	33
102	Fx7(echoes)	36	83	15	62	-1	3	C3	0	38	26
103	Fx8(sci-fi)	36	83	15	62	-1	3	C3	0	38	26
104	Sitar	48	77	27	56	0	3	3	0	32	20
105	Banjo	48	84	27	63	0	3	3	0	39	27
106	Shamisen	50	79	29	58	0	5	5	0	34	22
107	Koto	55	84	34	63	0	10	A	0	39	27
108	Kalimba	48	79	27	58	0	3	3	0	34	22
109	Bag pipe	36	77	15	56	-1	3	C3	0	32	20
110	Fiddle	55	91	34	70	0	10	A	0	46	2E
111	Shanai	48	72	27	51	0	3	3	0	27	1B
112	Tinkle Bell	72	77	51	56	0	27	1B	0	32	20
113	Agogo	60	72	39	51	0	15	F	0	27	1B
114	Steel Drums	52	76	31	55	0	7	7	0	31	1F
115	Woodblock	36	84	15	63	-1	3	C3	0	39	27
116	Taiko	36	72	15	51	-1	3	C3	0	27	1B
117	Melodic Tom	36	94	15	73	-1	3	C3	0	49	31
118	Synth Drum	36	94	15	73	-1	3	C3	0	49	31
119	Reverse Cymbal	36	84	15	63	-1	3	C3	0	39	27
120	Guitar Fret Noise	36	72	15	51	-1	3	C3	0	27	1B
121	Breath Noise	36	72	15	51	-1	3	C3	0	27	1B
122	Seashore	36	72	15	51	-1	3	C3	0	27	1B
123	Bird Tweet	36	72	15	51	-1	3	C3	0	27	1B
124	Telephone Ring	36	72	15	51	-1	3	C3	0	27	1B
125	Helicopter	36	72	15	51	-1	3	C3	0	27	1B
126	Applause	36	72	15	51	-1	3	C3	0	27	1B
127	Gunshot	36	72	15	51	-1	3	C3	0	27	1B
128	Acoustic Bass Drum	-	-	0	0	-	-	-	-	-	-
129	Bass Drum1	-	-	1	1	-	-	-	-	-	-
130	Side Stick	-	-	2	2	-	-	-	-	-	-
131	Acoustic Snare	-	-	3	3	-	-	-	-	-	-
132	Hand Clap	-	-	4	4	-	-	-	-	-	-
133	Electric Snare	-	-	5	5	-	-	-	-	-	-
134	Low Floor Tom	-	-	6	6	-	-	-	-	-	-
135	Closed Hi-Hat	-	-	7	7	-	-	-	-	-	-
136	High Floor Tom	-	-	8	8	-	-	-	-	-	-
137	Pedal Hi-Hat	-	-	9	9	-	-	-	-	-	-
138	Low Tom	-	-	10	10	-	-	-	-	-	-
139	Open Hi-Hat	-	-	11	11	-	-	-	-	-	-
140	Low-Mid Tom	-	-	12	12	-	-	-	-	-	-
141	Hi-Mid Tom	-	-	13	13	-	-	-	-	-	-
142	Crash Cymbal1	-	-	14	14	-	-	-	-	-	-
143	High Tom	-	-	15	15	-	-	-	-	-	-
144	Ride Cymbal1	-	-	16	16	-	-	-	-	-	-
145	Chinese Cymbal	-	-	17	17	-	-	-	-	-	-

Date	Specification
ROHM CO.,LTD.	Specification No. Ver.E

146	Ride Bell	-	-	18	18	-	-	-	-	-	-
147	Tambourine	-	-	19	19	-	-	-	-	-	-
148	Splash Cymbal	-	-	20	20	-	-	-	-	-	-
149	Cowbell	-	-	21	21	-	-	-	-	-	-
150	Crash Cymbal2	-	-	22	22	-	-	-	-	-	-
151	Vibraslap	-	-	23	23	-	-	-	-	-	-
152	Ride Cymbal2	-	-	24	24	-	-	-	-	-	-
153	Hi Bongo	-	-	25	25	-	-	-	-	-	-
154	Low Bongo	-	-	26	26	-	-	-	-	-	-
155	Mute Hi Conga	-	-	27	27	-	-	-	-	-	-
156	Open Hi Conga	-	-	28	28	-	-	-	-	-	-
157	Low Conga	-	-	29	29	-	-	-	-	-	-
158	High Timbale	-	-	30	30	-	-	-	-	-	-
159	Low Timbale	-	-	31	31	-	-	-	-	-	-
160	High Agogo	-	-	32	32	-	-	-	-	-	-
161	Low Agogo	-	-	33	33	-	-	-	-	-	-
162	Cabasa	-	-	34	34	-	-	-	-	-	-
163	Maracas	-	-	35	35	-	-	-	-	-	-
164	Short Whistle	-	-	36	36	-	-	-	-	-	-
165	Long Whistle	-	-	37	37	-	-	-	-	-	-
166	Short Guiro	-	-	38	38	-	-	-	-	-	-
167	Long Guiro	-	-	39	39	-	-	-	-	-	-
168	Clavas	-	-	40	40	-	-	-	-	-	-
169	Hi Wood Block	-	-	41	41	-	-	-	-	-	-
170	Low Wood Block	-	-	42	42	-	-	-	-	-	-
171	Mute Cuica	-	-	43	43	-	-	-	-	-	-
172	Open Cuica	-	-	44	44	-	-	-	-	-	-
173	Mute Triangle	-	-	45	45	-	-	-	-	-	-
174	Open Triangle	-	-	46	46	-	-	-	-	-	-
175	Cursor move sound 1 (Short)	-	-	47	47	-	-	-	-	-	-
176	Cursor move sound 2 (Long)	-	-	48	48	-	-	-	-	-	-
177	Beep (Normal)	-	-	49	49	-	-	-	-	-	-
178	Beep (Outer space)	-	-	50	50	-	-	-	-	-	-
179	Siren1	-	-	51	51	-	-	-	-	-	-
180	Character power up	-	-	52	52	-	-	-	-	-	-
181	Character get	-	-	53	53	-	-	-	-	-	-
182	Up	-	-	54	54	-	-	-	-	-	-
183	Down	-	-	55	55	-	-	-	-	-	-
184	Luffin	-	-	56	56	-	-	-	-	-	-
185	Scream	-	-	57	57	-	-	-	-	-	-
186	Pretty	-	-	58	58	-	-	-	-	-	-
187	Mystery	-	-	59	59	-	-	-	-	-	-
188	Robot	-	-	60	60	-	-	-	-	-	-
189	Foot step	-	-	61	61	-	-	-	-	-	-
190	Character rotation	-	-	62	62	-	-	-	-	-	-
191	Character jump	-	-	63	63	-	-	-	-	-	-
192	Laser gun (Short)	-	-	64	64	-	-	-	-	-	-
193	Hit1 (Hard)	-	-	65	65	-	-	-	-	-	-
194	Hit2 (Noise)	-	-	66	66	-	-	-	-	-	-
195	Bomb (Short)	-	-	67	67	-	-	-	-	-	-
196	Bomb (Long)	-	-	68	68	-	-	-	-	-	-
197	Monster damage	-	-	69	69	-	-	-	-	-	-
198	Robot damage	-	-	70	70	-	-	-	-	-	-
199	Character fade out	-	-	71	71	-	-	-	-	-	-
200	Engine	-	-	72	72	-	-	-	-	-	-
201	Approach (Fade in)	-	-	73	73	-	-	-	-	-	-
202	Take off (Fade out)	-	-	74	74	-	-	-	-	-	-
203	Space (Filter drown)	-	-	75	75	-	-	-	-	-	-
204	Science (Hi drown)	-	-	76	76	-	-	-	-	-	-
205	Bubble	-	-	77	77	-	-	-	-	-	-

Date	Specification
ROHM CO.,LTD.	Specification No. Ver.E

206	Drop	-	-	78	78	-	-	-	-	-	-
207	Reserved	-	-	-	-	-	-	-	-	-	-
208	Reserved	-	-	-	-	-	-	-	-	-	-
209	Reserved	-	-	-	-	-	-	-	-	-	-
210	Reserved	-	-	-	-	-	-	-	-	-	-
211	Reserved	-	-	-	-	-	-	-	-	-	-
212	Reserved	-	-	-	-	-	-	-	-	-	-
213	Reserved	-	-	-	-	-	-	-	-	-	-
214	Reserved	-	-	-	-	-	-	-	-	-	-
215	Reserved	-	-	-	-	-	-	-	-	-	-
216	Reserved	-	-	-	-	-	-	-	-	-	-
217	Reserved	-	-	-	-	-	-	-	-	-	-
218	Reserved	-	-	-	-	-	-	-	-	-	-
219	Reserved	-	-	-	-	-	-	-	-	-	-
220	Reserved	-	-	-	-	-	-	-	-	-	-
221	Reserved	-	-	-	-	-	-	-	-	-	-
222	Special rectangle	21	108	0	87	-2	0	80	0	63	3F
223	Special rectangle	21	108	0	87	-2	0	80	0	63	3F
224	Special rectangle	21	108	0	87	-2	0	80	0	63	3F
225	Sin wave	21	108	0	87	-2	0	80	0	63	3F
226	Sin wave	21	108	0	87	-2	0	80	0	63	3F
227	Sin wave	21	108	0	87	-2	0	80	0	63	3F
228	Reserved	-	-	-	-	-	-	-	-	-	-
229	Reserved	-	-	-	-	-	-	-	-	-	-
230	Reserved	-	-	-	-	-	-	-	-	-	-
231	Reserved	-	-	-	-	-	-	-	-	-	-
232	Reserved	-	-	-	-	-	-	-	-	-	-
233	Reserved	-	-	-	-	-	-	-	-	-	-
234	Reserved	-	-	-	-	-	-	-	-	-	-
235	Reserved	-	-	-	-	-	-	-	-	-	-
236	Reserved	-	-	-	-	-	-	-	-	-	-
237	Reserved	-	-	-	-	-	-	-	-	-	-
238	Reserved	-	-	-	-	-	-	-	-	-	-
239	Reserved	-	-	-	-	-	-	-	-	-	-
240	Reserved	-	-	-	-	-	-	-	-	-	-
241	Reserved	-	-	-	-	-	-	-	-	-	-
242	Reserved	-	-	-	-	-	-	-	-	-	-
243	Reserved	-	-	-	-	-	-	-	-	-	-
244	Reserved	-	-	-	-	-	-	-	-	-	-
245	Reserved	-	-	-	-	-	-	-	-	-	-
246	Reserved	-	-	-	-	-	-	-	-	-	-
247	Reserved	-	-	-	-	-	-	-	-	-	-
248	Reserved	-	-	-	-	-	-	-	-	-	-
249	Reserved	-	-	-	-	-	-	-	-	-	-
250	Reserved	-	-	-	-	-	-	-	-	-	-
251	Reserved	-	-	-	-	-	-	-	-	-	-
252	Reserved	-	-	-	-	-	-	-	-	-	-
253	Reserved	-	-	-	-	-	-	-	-	-	-
254	Reserved	-	-	-	-	-	-	-	-	-	-
255	Reserved	-	-	-	-	-	-	-	-	-	-

Date	Specification
ROHM CO.,LTD.	Specification No. Ver.E

10. ADPCM decoder

This ADPCM performs reproduction with sampling rates of 4KFs and 8 KFs.

Users can produce favorable sound effects with this decoder.

[Outline of the performance]

- 1) Preset encode data corresponding to this decoder are prepared.
- 2) In ADPCM FIFO Clear bit, "1" is written.
- 3) Encoded data are loaded in the ADPCM FIFO.
- 4) By writing "1" in the ADPCM Start bit, reproduction starts.
- 5) Data are continuously sent to the FIFO so that it may not be emptied.
- 6) Detecting "FIFO empty" or by writing "1" in the Tmute bit stops reproduction from the ADPCM.
- 7) When ADPCM BUSY="L" is detected, write "0" in ADPCM start bit.
- 8) After stopping play, execute from step 1) above to start play again.

11. Synchronous melody LED control

LEDOUT terminal is controlled in the following two ways:

- 1) LEDON by the CPU
Write "1" in address 0x19 to set LED output to "H".
- 2) LEDON by melody synchronizing using the sequencer (bit4 of address 0x03, LED IntEnb is set to "1").
When the playing data specified to be main melody (TrackNo.0, VoiceNo.0) starts, LED output="H".
The firmware can recognize LEDON by LED interrupt.
In the firmware, this interrupt shall be cleared instantly.
- 3) LEDOFF
In each case of 1) and 2) above, LED output = "L" by writing "0" in address 0x19.

LED output by melody synchronizing

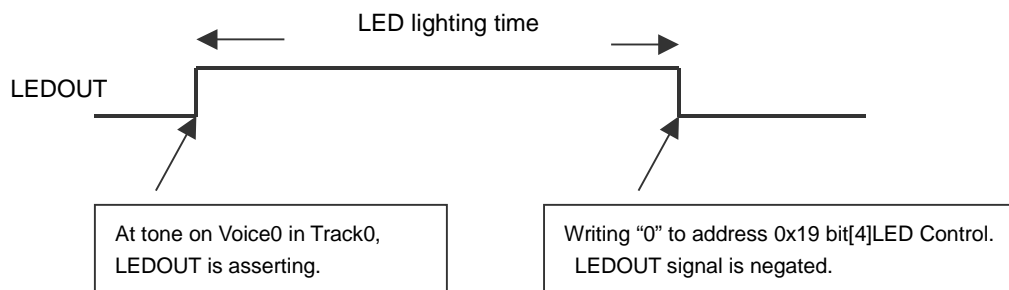

Date	Specification
ROHM CO.,LTD.	Specification No. Ver.E

12. Playtime control function

This IC is provided with a playtime control function.

An interrupt is generated in the CPU to monitor playtime of a melody.

Interval Timer Interrupt : The built-in interval timer starts to operate when the MIDI sequencer starts.

This timer generates an interrupt in the CPU with a value expressed by the address 0x0E.

In case of using this timer, When sound source is directly controlled from the CPU, start the sequencer to make the timer active. And empty the FIFO not to make performe to the sequencer.

The interrupt with this timer can be used by starting the sequencer after emptying the FIFO.

Call Back Message : The expansion of the sequencer performance data format (0xFA) is used.

During performance, when the sequencer detects this message, it expresses the during-message status in the register and generates the interrupt signal. By using this message it is possible to generate the interrupt at any arbitrary point.

Date	Specification
ROHM CO.,LTD.	Specification No. Ver.E

[Design memo]

Compact MIDI format processing flow example

Making address 0x00: bit [2]AN1/2 'L', a performance data format selects the format A.

Case of TrackNo0 - 15.

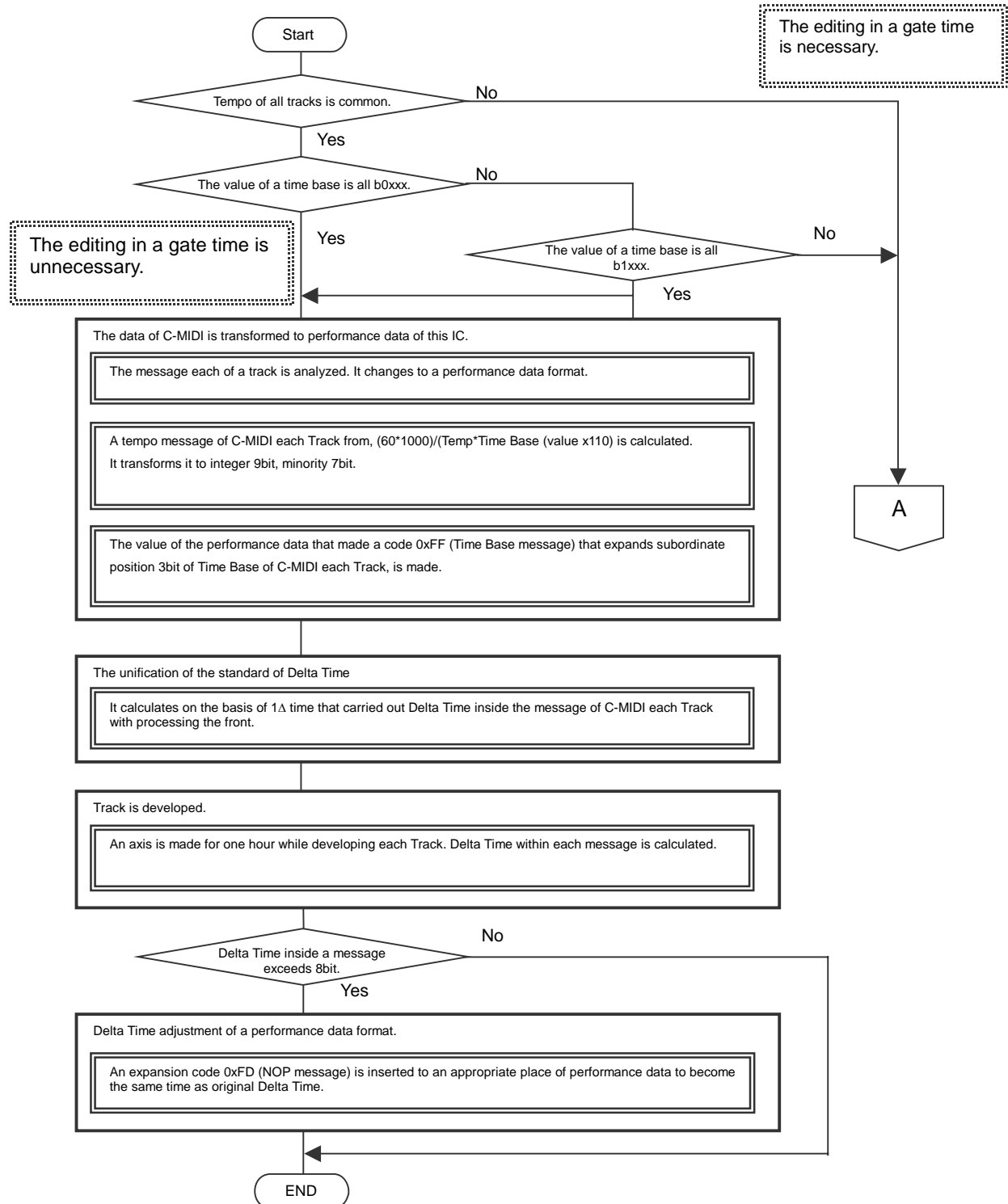

Date	Specification
ROHM CO.,LTD.	Specification No. Ver.E

After Track16, and Temp and Time Base are not common.

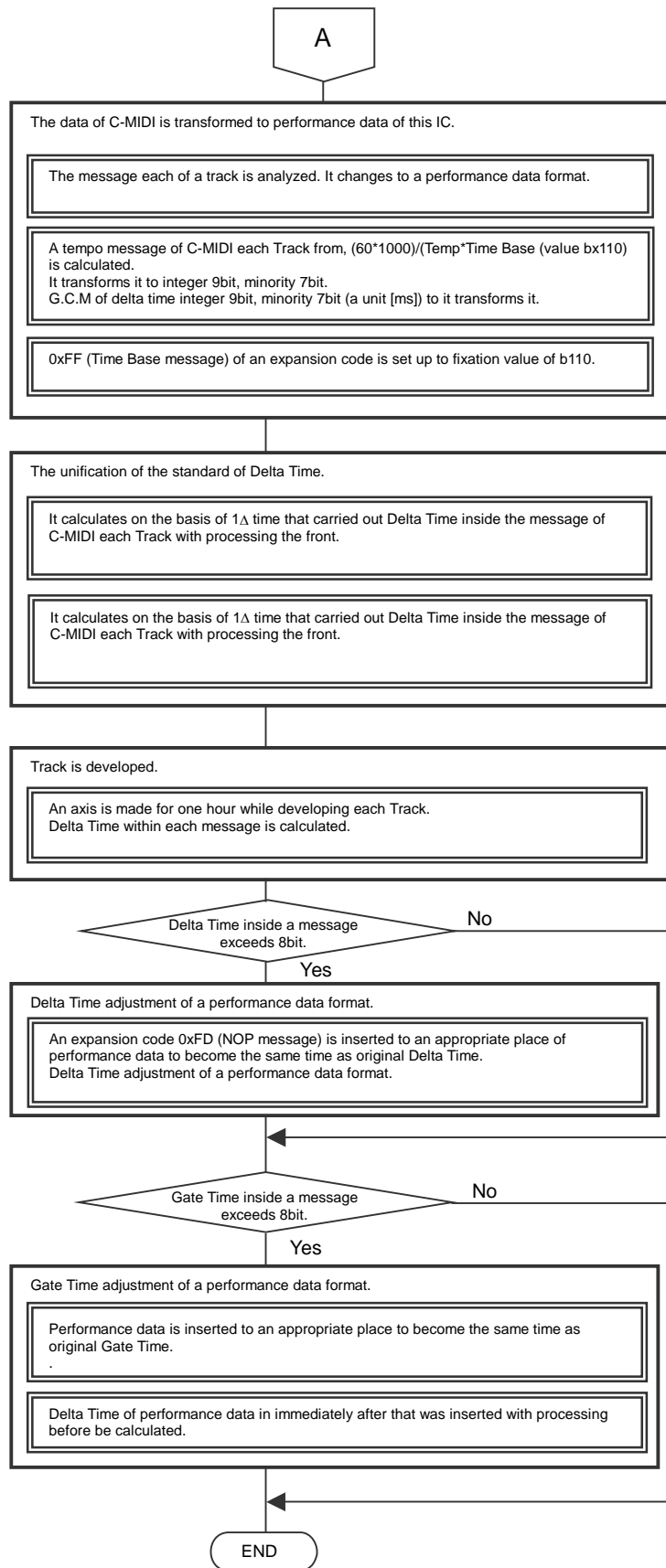

Date	Specification
ROHM CO.,LTD.	Specification No. Ver.E

[Design memo]

Performance data control of FIFO empty

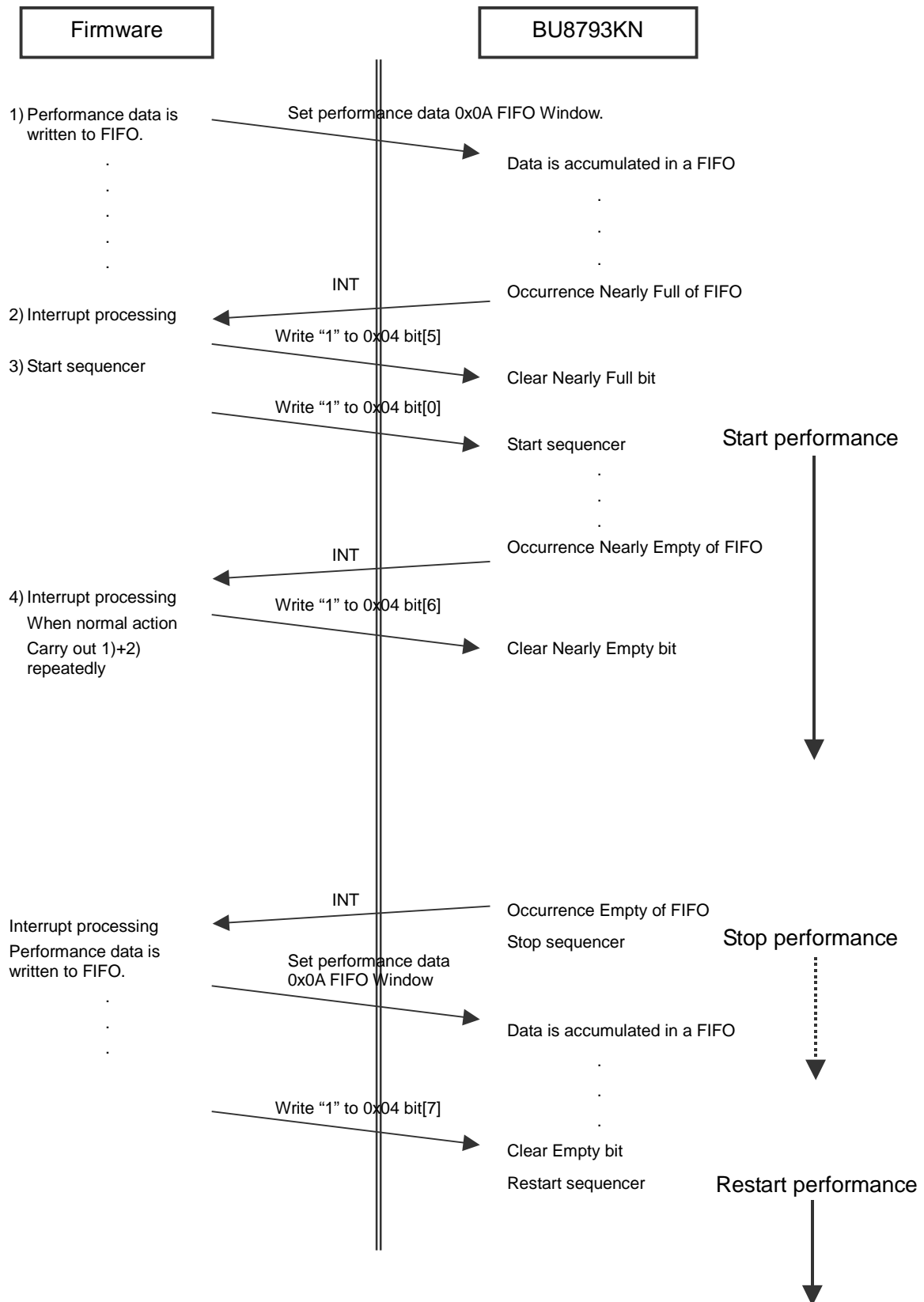

Date	Specification
ROHM CO.,LTD.	Specification No. Ver.E

[Memo]

Performance data is processed every format block.
 If Bu8793 detects empty of FIFO with a block each exception actually.
 Sequencer stop, Performance discontinuation, sets 0x04bit[3] illegal format.
 It must carry out setting after Firm Ware reset 0x04bit[3].
 It is Clear of FIFO. And the sequencer prepares restart.
 Accordingly, it's desirable to transmit every a format block.

Format block: means block of note message format
 In case of format A is 7 Bytes.
 In case of format B, 6 Bytes at note on message, 3 Bytes at note off Message.

[Design memo]

For example: To play Drum set of Compact MIDI.

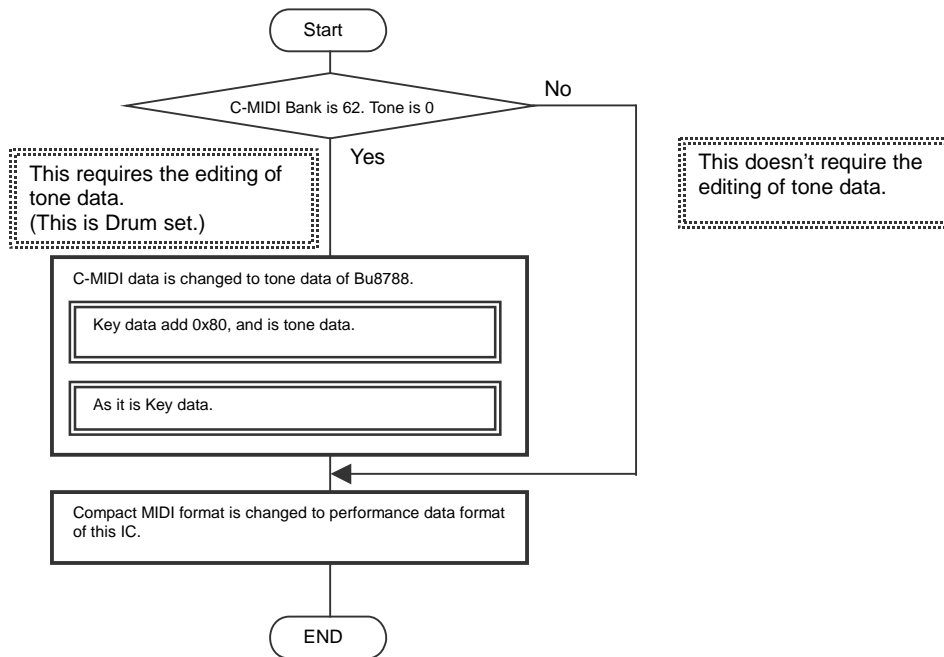

Date	Specification
ROHM CO.,LTD.	Specification No. Ver.E