

公差/General Tolerances(mm)		公差/General Tolerances(mm)	
0	>3	>18	>30
~	>6	>18	>30
~	>10	>18	>30
~	>18	>30	>50
~	>30	>50	>80
~	>50	>80	>120
~	>80	>120	>180
~	>120	>180	>250
~	>180	>250	>315
~	>250	>315	>400
~	>315	>400	>500
~	>400	>500	>630
~	>500	>630	>800
~	>630	>800	>1000
±0.12	±0.18	±0.22	±0.26
±0.31	±0.37	±0.57	±0.80
±1.09	±1.15	±1.60	±2.20
±2.50	±2.50	±2.50	±2.50
0.1/10	0.1/10	0.1/10	0.1/10
±Z	±Z	±Z	±Z

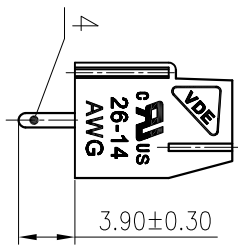

PCB LAYOUT

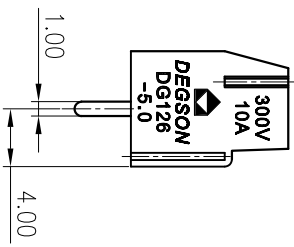
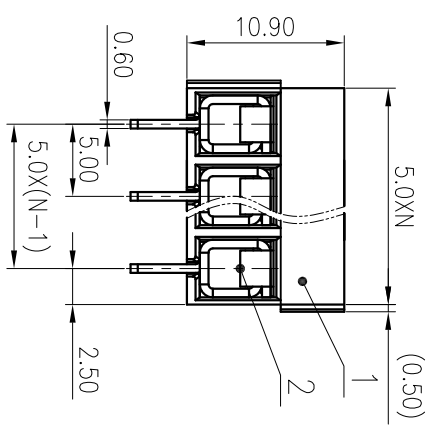
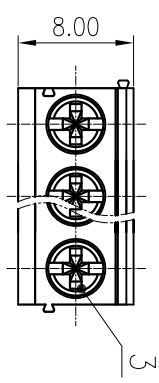
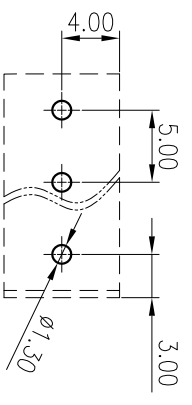

MATERIAL:	SURFACE: /		
MAT NO.:	/		
STATUS:	/		
APPD: LanChH	2020.05.19	NAME:	NINGBO DEGSON ELECTRICAL CO., LTD
CHKD: YuJZ	2020.05.19	DRAWING NO.:	10002118
DRT: ChenZh	2020.05.19	TYPE: CUSTOMER DRAWING	SCALE: 2:1
REV	ECN	DESCRIPTION	DRT
1	2	3	4
REV	ECN	DESCRIPTION	DRT
1	2	3	4

4	Pin header	Copper alloy	Sn plated
3	Screw	Steel	M2.6/Zn plated
2	Spring	Stainless steel	
1	Housing	PA66	UL94V-0
ITEM	NAME OF PART	MATERIAL	NOTES
UL 标准/UL Standard:	B	C	D
额定电压/Rated Voltage(V)/Current(A)	300/10	/	/
EC 标准/IEC Standard:			
过压类别/Overvoltage Category/污染等级/Pollution Degree		III/2	
额定电压/电流/Rated Voltage(V)/Current(A)		250/18	
工频耐压/Withstanding voltage(V/1Min)		AC2000	
螺丝扭矩/Torque Tightening(N·m/Lb.in)		M2.6, 0.24~0.40N·m/3.06~3.54Lb.in	
线径范围(硬线和软线)/Wire Range(rigid and flexible)(mm <sup>2</sup> /AWG)		0.5~2.5/26~14	
间距/Pitch(mm)/线数范围/Poles		5.0/N=02~24P	
剥线长度/Stripping length(mm)		6~7	
使用温度范围/Operating Temperature(°C)		-40~+105	
符合环保要求/Conform to RoHS		Yes	

D C B A

D C B A

1 2 3 4 5 6